

# LITETRONICS®

## LED Smart Light Panel Retrofit with Fixed CCT and Tunable Wattage

### Installation Instructions

PRTYXXN-Series | 2' x 2', 2' x 4' & 1' x 4'

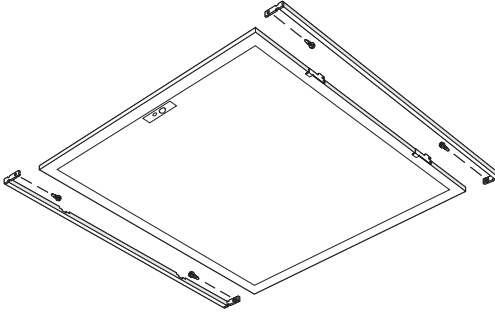

#### WHAT COMES IN THE BOX

- |                                     |                     |
|-------------------------------------|---------------------|
| LLED Light Panel Retrofit panel (1) | Safety cables (2)   |
| Mounting rails (2)                  | Quick Connect (1)   |
| Wire nuts (1)                       | Luminaire label (1) |
| Self tapping screws (6)             | Velcro Tape (4)*    |
| Installation Instructions (1)       |                     |

\*Required for 2' x 4' for relocating the driver, if applicable.

#### TOOLS NEEDED

- Screwdriver or power drill

## SAFETY INSTRUCTIONS AND WARNINGS

### WARNINGS

Risk of fire or electric shock. LED Light Panel Retrofit kit installation requires knowledge of luminaire's electrical system. If not qualified, do not attempt installation. Contact a qualified electrician. Luminaire wiring and electrical parts may be damaged when drilling for installation of retrofit kit. Check for enclosed wiring and components. Do not make or alter any open holes in the enclosure of wiring or electrical components during kit installation.

Install this kit only in luminaires that have the construction features and dimensions shown in the photographs and/or drawings and where the input rating of the retrofit kit does not exceed the input rating of the luminaire. Only those open holes indicated in the photographs and/or drawings may be made or altered as a result of kit installation. Do not leave any other open holes in an enclosure of wiring or electrical components.

To prevent wiring damage or abrasion, do not expose wiring to edges of sheet metal or other sharp objects.

This LED Light Panel Retrofit kit shall only be installed into a UL/C-UL listed Fluorescent Recessed, Type IC or Non-IC, listed luminaire with a steel enclosure.

### DISCONNECT SAFETY INSTRUCTIONS:

This is a current rated device. Use in applications involving amperage beyond its rating can be dangerous and cause electrical fires. See note on this page for allowable current and voltage levels and do not exceed those levels.

Never remove wires from product as contact with electricity can cause serious injury or death. Shut off power at the circuit breaker or remove fuse when installing this product.

Improperly installed electrical wiring can be dangerous and cause electrical fires. This product must be used in accordance with the current rating and wire sizes listed.

**COPPER to COPPER ONLY.** Do not use on Aluminum. Temperature rating: 105° C (221° F) maximum. Flame Rated UL94V-0.

# INSTALLATION PROCEDURE

## READ ALL INSTRUCTIONS BEFORE BEGINNING INSTALLATION

### Preparation

1. Turn off power at the electrical panel.
2. Remove the lens/diffuser, tubes and ballast from the existing troffer.

### Rail installation

3. Insert mounting rails A and B on opposite sides between the troffer and the grid rail with anti-rotational tabs pointed inward and notches facing up. The troffer will need to be raised slightly to accommodate the rails. Once inserted, push rail B to the right until it is flush against the t-grid rail. This will ensure the locking hooks latch on to the rail and secure the fixture. See figure 1 for reference. For 2x2 size, the rails should be installed on the tapered sides of the troffer.

**For added security**, the rails can be secured to the t-grid. Once the rails are installed, insert the included self-tapping screws through the end tabs and drill into the t-grid as shown in figure 1.

### Panel installation

4. Locate the two panel hangers on the side edge of the panel. Insert the hangers into the notches on mounting rail A. This will allow the panel to hang freely. See figure 2 for reference.
5. Attach the two seismic safety cables from the panel to the troffer using self-tapping screws.
6. Connect power wires AC-L (Black) and AC-N (White) into the open side of the quick-connect.
7. Connect the ground wire using the supplied wire nut.
8. Apply the luminaire label to the inside of the troffer.
9. Locate the panel hooks (2) on the panel and rotate them to the open or install position.
10. Swing the panel up so it's even with the ceiling. Then rotate the hooks (2) so that they engage the rail tabs.
11. Panel should be flush to ceiling.
12. Your installation is complete. Once all retrofit kits have been installed you can restore power.

## SENSOR CONTROLS

The LED Smart Light Panel Retrofit is equipped with a built-in PIR sensor, which enables wireless control of various functions, such as occupancy sensing, daylight harvesting and dimming. The following options are available for controlling your LED Smart Light Panel Retrofit.



**LiteSmart\*** mobile app – Available in the app store for download to either IOS or Android devices.

LiteSmart offers complete control over your fixtures; includes occupancy sensing, daylight harvesting, dimming, grouping, time schedule programming and scene creation.

A supplemental app, **LiteBright\***, enables additional energy management functionality with the ability to set the max wattage of your fixtures.



**Bluetooth Control Switch** – Available for purchase from Litetronics under part # **BCS02**, **#BCS03**, and **#BCS05**.

This wireless bluetooth switch offers control over your fixture from a remote location, enabling quick access to on/off functionality as well as dimming control, daylight harvesting and scene selection.

Note: Switch doesn't have CCT tuning capability.

\* A detailed user guide for LiteSmart can be viewed or downloaded from [Litetronics.com](http://Litetronics.com)

### SENSOR DEFAULT SETTINGS\*\*

OCCUPANCY SENSING	HOLD TIME - FULL POWER	HOLD TIME - 50% POWER
On	20 minutes	1 minute

\*\*To adjust settings for occupancy sensing, enable daylight harvesting or to group and program fixtures, download the LiteSmart mobile app.

# INSTALLATION PROCEDURE

figure 1

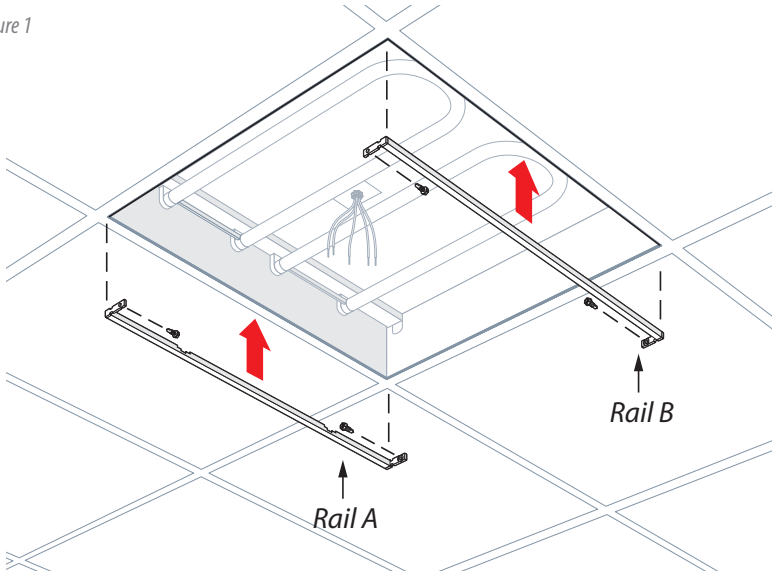
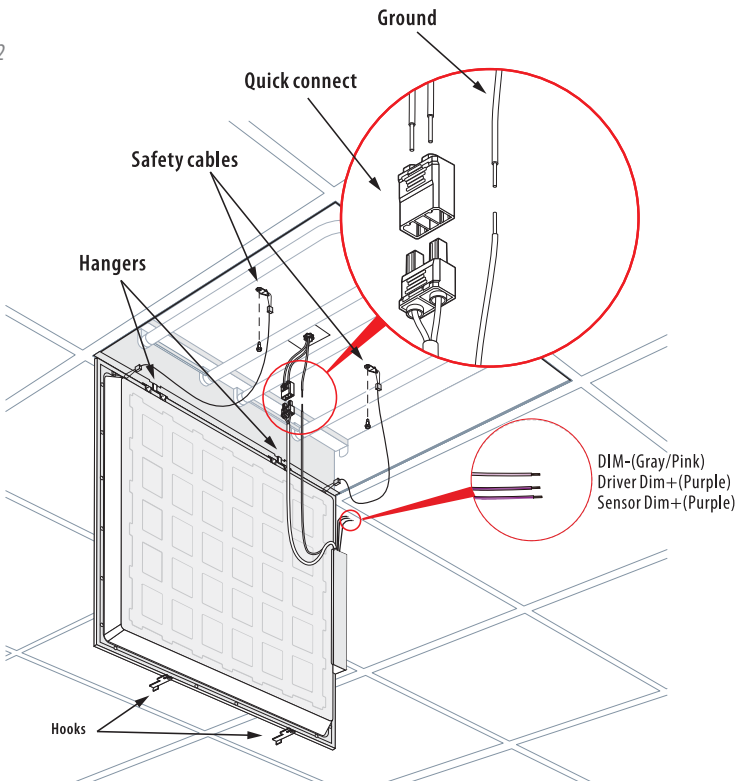

figure 2



Thank you for choosing

**LITETRONICS®**

6969 W. 73rd Street  
Bedford Park, IL 60638

WWW.LITETRONICS.COM

CustomerService@Litetronics.com or 1-800-860-3392



The information and product specifications contained in these instructions are based upon data believed to be accurate at the time of printing. This information is subject to change without notice and without incurring liability. If you have questions regarding specific product details, please contact us at 800-860-3392 or via email at [customerservice@litetronics.com](mailto:customerservice@litetronics.com).

To check for an updated version of these instructions, please visit [www.litetronics.com](http://www.litetronics.com).

9/21/23 - V4.5