

PROJECT:	
CATALOG #	
TYPE:	DATE:

## LED VOLUMETRIC TROFFER (C-SERIES)

### SELECTABLE OUTPUT SERIES

#### DESCRIPTION

Combining top-of-the-line efficiency, versatility, and a stylish, modern design, our line of LED Volumetric Troffers offers ideal solutions for a wide range of interior applications.

Our Selectable Output Series features field-selectable wattage and CCT, enabling a wide range of output options from a single fixture. Our 2' x 4' includes up to 5 unique lumen levels while the 2' x 2' and 1' x 4' include up to 3 unique lumen levels. Each fixture offer 3 options for color temperature (3500K, 4000K, 5000K). Also, each wattage is individually qualified with the DLC to ensure the best rebates based on the actual energy usage.

Installation is simple and quick; this LED troffer upgrade fits seamlessly into all standard 2' x 4', 2' x 2', and 1' x 4' ceiling layouts. It can also be recessed into drywall ceiling applications, surface mounted or suspension mounted as alternatives.

The LED Volumetric Troffer delivers up to 125 lumens per watt (LPW) over the course of it's 50,000-hour rated life. It ensures long-term energy savings over traditional fluorescent bulbs and ballasts, as well as eliminates routine maintenance, making it perfect for updating existing grid layouts or implementing in new construction. Furthermore, it's backed by an industry-leading 5-year warranty, guaranteeing peace of mind for the life of your fixture.

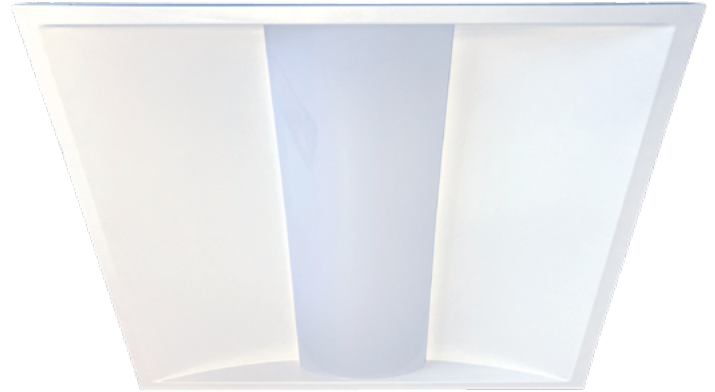

#### FEATURES

- Selectable wattage
  - 2' x 4'
  - 2' x 2' and 1' x 4'
- Selectable CCT (3500K, 4000K, 5000K)
- DLC 5.1 Premium (up to 125 LPW)
- Size options: 2' x 4', 2' x 2', 1' x 4'
- UL Damp location rating
- IC rated
- 0-10V Dimming
- 50,000-hour rated life
- 5-year warranty
- Compatible with Emergency Battery Backup
- Easy installation
- Grid, suspension, surface or recessed mounting

#### MOUNTING

- Grid ceiling
- Surface Mount
- Suspension
- Recessed drywall

#### MARKETS

- Schools and universities
- Retail
- Offices and municipal buildings
- Hospitality back of house
- Healthcare facilities and hospitals
- Conference centers
- Commercial

#### CERTIFICATIONS



## SPECIFICATIONS

**Life (@L70):** 50,000 hours

**Warranty:** 5 years

### PERFORMANCE

**Operating temp:** -4°F to 113°F (-20°C to 45°C)

**Efficacy (LPW):** 125 LPW

**CRI:** 80

### ELECTRICAL

**Input voltage:** 120-277V

**Input frequency:** 50/60Hz

**PF:** ≥.95

**THD:** ≤20%

**Surge protection:** ANSI C82.77 compliant

**Dimming:** 0-10VDC ANSI C137.x compliant

**Minimum dimming:** 0% of rated lumen

**Aux. Voltage:** No

**Driver CL:** N/A

**Whip/Cord:** No

**Sensor:** No

### OPTICAL

**Beam:** 110°

**Lens:** Polycarbonate Frosted

**UGR:** 22

### PHYSICAL

**Finish:** Powder Coat

**Color:** White

**Housing:** Painted Steel

### INDUSTRY STANDARDS/RATINGS

**IP:** 20

**IK:** N/A

**Location:** Damp

**IC:** VLCT4 - Yes

VLCT2 - Yes

VLCT1 - Yes

**UL/ETL:** UL

**FCC:** Yes

**RoHS:** Yes

**DLC:** 5.1 Premium

## MOUNTING

**Standard:** T-bar grid (drop ceilings)

**Wiring access:** 1/2" trade size knockouts

## ACCESSORIES

**Emergency Battery Backup  
Surface Mounting Kit**

**Drywall Mounting Kit  
Suspension Mounting Kit**

## DIMENSIONS / WEIGHT

ORDER#	SIZE	LENGTH	WIDTH	HEIGHT	WEIGHT
VLCT4	2' x 4'	47.76"	23.82"	1.97"	11.44 lbs.
VLCT2	2' x 2'	23.82"	23.82"	1.97"	6.139 lbs.
VLCT1	1' x 4'	47.76"	11.93"	1.97"	8.133 lbs.

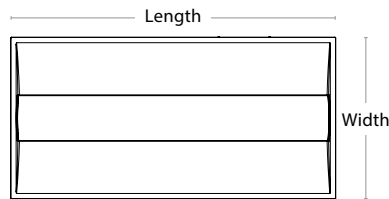

Panel (2' x 4' shown here)

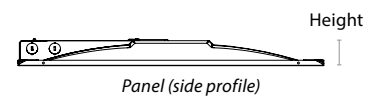

## PRODUCT OVERVIEW AND INSTALLATION

### STANDARD GRID CEILING MOUNTING

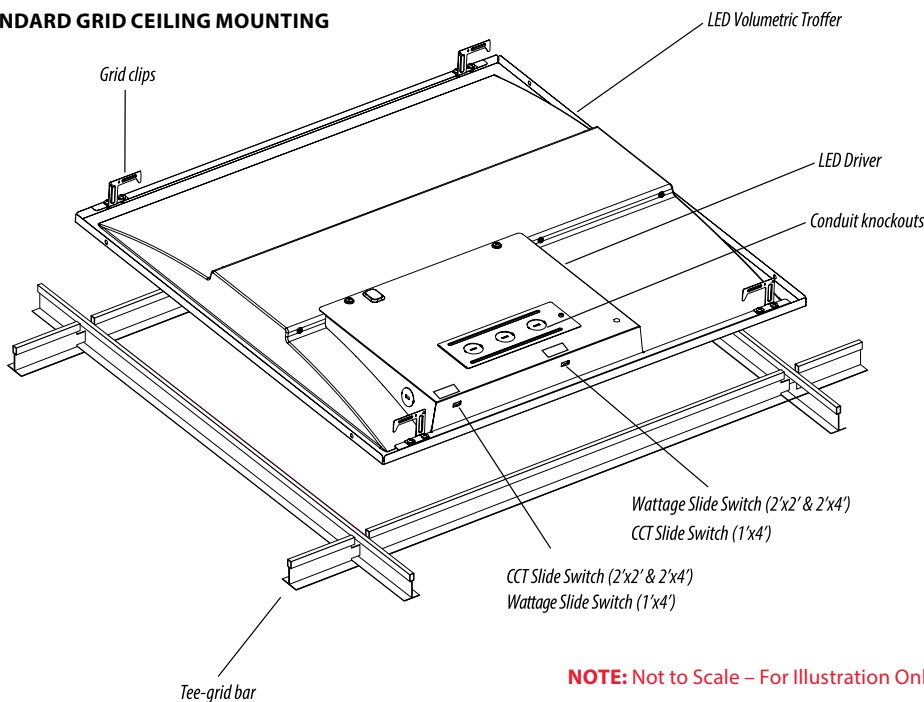

### ALTERNATIVE MOUNTING OPTIONS

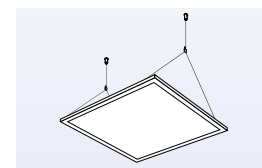
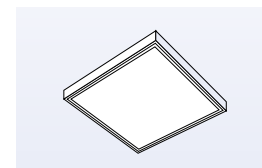
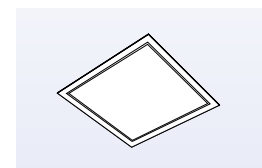

**NOTE:** Not to Scale – For Illustration Only.

Litetronics, Inc. | 6969 W. 73rd St. Bedford Park, IL 60638 | Tel:1-800-860-3392 | customerservice@litetronics.com

[www.Litetronics.com](http://www.Litetronics.com)

## ORDERING INFORMATION

Listed below are the max wattage settings and lumens for each model number.

ORDERING CODE	DESCRIPTION	SIZE	WATTS	VOLTS	CCT (K)	LUMENS
VLCT4	LED Volumetric Troffer	2' x 4'	30   40   50	120-277V	3500   4000   5000	3750   5000   6250
VLCT2	LED Volumetric Troffer	2' x 2'	20   25   30		3500   4000   5000	2500   3125   3750
VLCT1	LED Volumetric Troffer	1' x 4'	20   25   30		3500   4000   5000	2500   3125   3750



## EMERGENCY BATTERY BACKUP

MODEL #	DESCRIPTION	USAGE
EB10	10W Emergency Battery Backup	Supplies battery backup to an individual fixture for up to 90 minutes. <u>Must be ordered with EBCM or EBAM indicator module.</u>
EBCM	Ceiling-Mounted Indicator Module	This Ceiling-Mounted Indicator Module (EBCM) can be used with one of Litetronics' emergency battery backup products (EB10, EB10N or EB20) to provide a visual confirmation of the operational status of the EBB unit. This module is typically used in grid ceiling applications where it is recess mounted in a panel adjacent to the fixture.
EBAM	Adhesive-Mounted Indicator Module	This Adhesive-Mounted Indicator Module (EBAM) must be used with one of Litetronics' emergency battery backup products (EB10, EB10N or EB20) to provide a visual confirmation of the operational status of the EBB unit. This module is typically used in open ceiling or drywall ceiling applications where the module is applied to the side of the fixture, mounting kit, or a nearby structural element.
TR01	LED Emergency Light Test Remote	This accessory is required to operate and test the EMBB. <ul style="list-style-type: none"> <li>• Only one remote required per area, building or site as necessary.</li> </ul>

## DRYWALL MOUNT KIT

MODEL #	DESCRIPTION	USAGE	OUTSIDE DIMENSIONS
PADMT4	2x4 Drywall Mount Kit	Recess mount 2x4 Panels in ceiling surfaces	47.85" x 23.94" x 2.44"
PADMT2	2x2 Drywall Mount Kit	Recess mount 2x2 Panels in ceiling surfaces	24.07" x 23.94" x 2.44"
PADMT1	1x4 Drywall Mount Kit	Recess mount 1x4 Panels in ceiling surfaces	47.85" x 11.97" x 2.44"

### DRYWALL MOUNT KIT

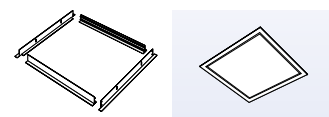

## SURFACE MOUNT KIT

MODEL #	DESCRIPTION	USAGE	OUTSIDE DIMENSIONS
VASSMT4	2x4 Surface Mount Kit	Surface mount 2x4 Panels to ceiling surfaces	47.85" x 23.94" x 3.1875"
VASSMT2	2x2 Surface Mount Kit	Surface mount 2x2 Panels to ceiling surfaces	24.07" x 23.94" x 3.1875"
VASSMT1	1x4 Surface Mount Kit	Surface mount 1x4 Panels to ceiling surfaces	47.85" x 11.97" x 3.1875"

### SURFACE MOUNT KIT

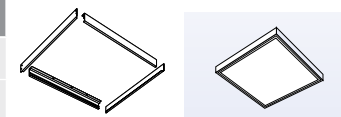

## SUSPENSION MOUNT KIT

MODEL #	DESCRIPTION	USAGE	WEIGHT RATING	DISTANCE FROM CEILING
PAMT4	2x4 Suspension Mount Kit	Suspend 2x4 Panels from ceiling	25 lbs	4.45'
PAMT2	2X2 Suspension Mount Kit	Suspend 2x2 Panels from ceiling	25 lbs	4.45'
PAMT1	1X4 Suspension Mount Kit	Suspend 1x4 Panels from ceiling	25 lbs	4.45'

### SUSPENSION MOUNT KIT

