

LITETRONICS®

LED Volumetric Troffer (C-Series)

Installation Instructions

VLC-Series | 2' x 2', 2' x 4' & 1' x 4'

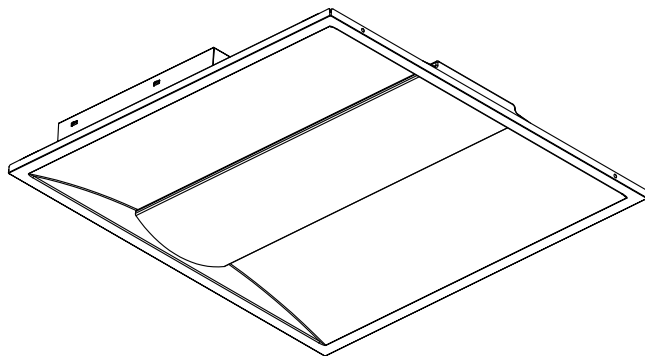

WHAT COMES IN THE BOX

LED Volumetric Troffer
Wire Nut (x5)
Installation Instructions

TOOLS NEEDED

Phillips Screwdriver

SAFETY INSTRUCTIONS AND WARNINGS

WHEN USING ELECTRICAL EQUIPMENT, BASIC SAFETY PRECAUTIONS SHOULD ALWAYS BE OBSERVED. READ CAREFULLY BEFORE INSTALLING FIXTURE. RETAIN THESE INSTRUCTIONS FOR FUTURE REFERENCE.

Litetrronics fixtures must be wired in accordance with the National Electrical Code and all applicable local codes.

Risk of fire or electric shock. Volumetric Troffer installation requires knowledge of luminaires electrical systems. If not qualified, do not attempt installation. Contact a qualified electrician.

Be certain electrical power is OFF before and during installation and maintenance.

Volumetric Troffer must be connected to a wiring system with an equipment – grounding conductor.

Make sure the supply voltage is the same as the rated luminaire voltage.

Only the open holes indicated in the photographs and/or drawings may be made or altered as a result of this kit installation. Do not leave any other open holes in an enclosure of wiring or electrical components.

To prevent wiring damage or abrasion, do not expose wiring to edges of sheet metal or sharp objects.

No user serviceable parts inside of the Volumetric Troffer.

Suitable for damp locations.

Suitable for 9/16" or 15/16" Flat Tee Grid in both insulated ceilings and non-insulated ceilings. Access above ceiling required.

Vapor barrier must be suitable for 90° C.

Fixture to be independently supported to building structure.

INSTALLATION PROCEDURE

READ ALL INSTRUCTIONS BEFORE BEGINNING INSTALLATION

1. Turn off power at the electrical panel.
2. Remove the ceiling tile or existing fixture from the grid ceiling space.
3. Before installing, locate the four grid clips on your troffer; bend them up and out so they can rest on top of the grid.
4. Locate the wattage slide switch and CCT slide switch, which can be found on the outside of the driver, and adjust to the desired settings. See CCT and wattage settings on next page.
5. Tilt and raise the troffer up into the empty grid space, then lower until the grid clips catch on the tee-grid bar. Attach the troffer to the building with support wires (not included) using the hole in the grid clip.
6. Unscrew and remove the driver cover to access the input and dimming wires.
7. Remove one conduit knock-out from the driver, then run branch power wire from the conduit to the driver.
8. Connect power wires AC-L (Black) and AC-N (White) and ground wires (Green & Yellow) into corresponding driver wires. See wiring diagram for details.
9. If 0-10V dimming is required, connect incoming dimming lines to the DIM+ (Purple) and DIM- (Pink) wires. Follow dimmer manufacturers instruction.
10. Close the driver cover and secure it with the screw.
11. Replace the ceiling tiles, turn on the power and your installation is complete.

WIRING DIAGRAM

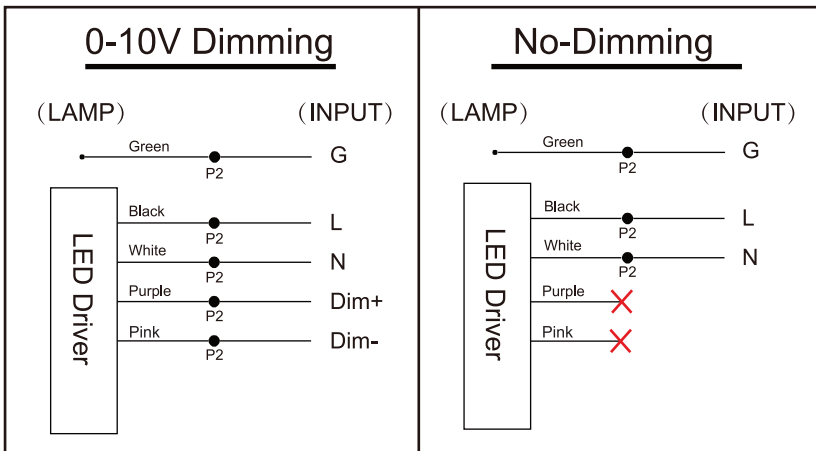

120V & 277V

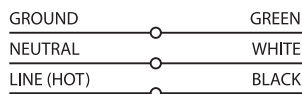

INSTALLATION PROCEDURE

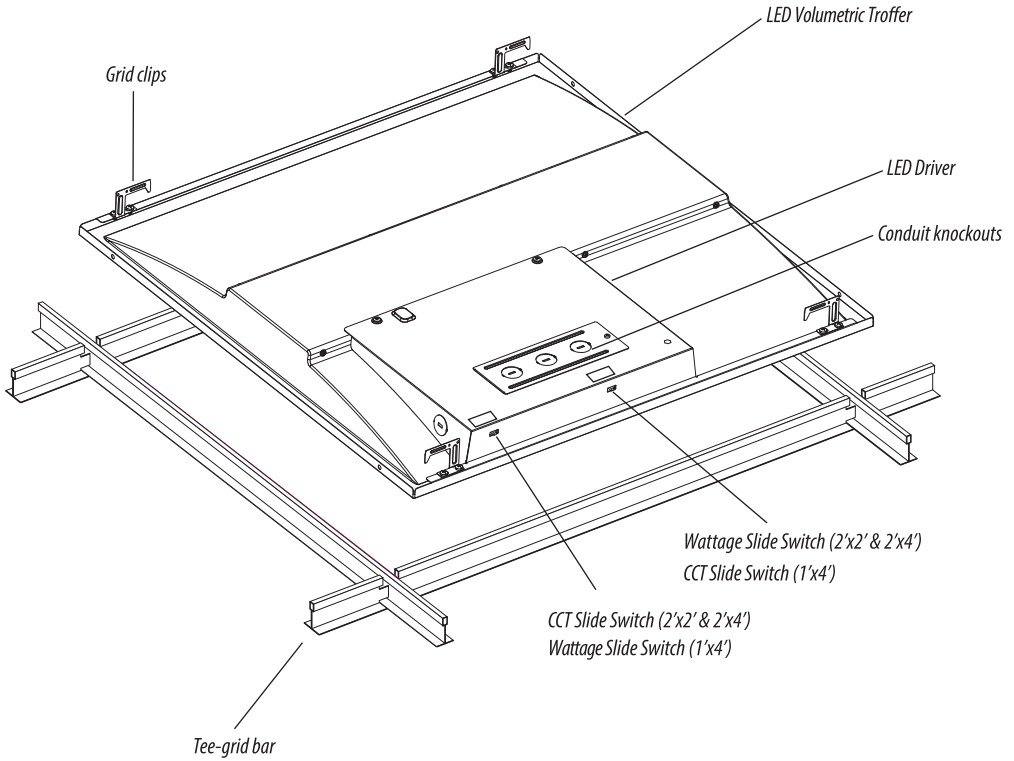

CCT and WATTAGE SETTINGS

CCT SWITCH SETTINGS 1'x4'

5000K	4000K	3500K
-------	-------	-------

WATTS SWITCH SETTINGS 1'x4'

40W	30W	20W
-----	-----	-----

Note: CCT default setting set to 4000K.
Watts default setting set to 40W.

CCT SWITCH SETTINGS 2'x2'

3500K	4000K	5000K
-------	-------	-------

WATTS SWITCH SETTINGS 2'x2'

20W	30W	40W
-----	-----	-----

Note: CCT default setting set to 4000K.
Watts default setting set to 40W.

CCT SWITCH SETTINGS 2'x4'

3500K	4000K	5000K
-------	-------	-------

WATTS SWITCH SETTINGS 2'x4'

30W	40W	50W
-----	-----	-----

Note: CCT default setting set to 4000K.
Watts default setting set to 50W.

Thank you for choosing

LITETRONICS®

6969 W. 73rd Street
Bedford Park, IL 60638

WWW.LITETRONICS.COM

CustomerService@Litetronics.com or 1-800-860-3392



The information and product specifications contained in these instructions are based upon data believed to be accurate at the time of printing. This information is subject to change without notice and without incurring liability. If you have questions regarding specific product details, please contact us at 800-860-3392 or via email at customerservice@litetronics.com.

To check for an updated version of these instructions, please visit www.litetronics.com.

REV: 04/15 /25 - V2.6