

PROJECT:	
CATALOG #	
TYPE:	DATE:

LED STRIP RETROFIT (C-SERIES) with Selectable Wattage and CCT

DESCRIPTION

The Contractor-Series Value LED Strip Retrofit mounts to your existing strip housing, significantly reducing installation time and resulting in modern efficiency with the polished look of a new fixture.

In just a few minutes, your fluorescent strip fixture can be converted to LED. The Strip Retrofit mounts to the existing housing, maintaining the current aesthetic, reducing disposal costs and also reducing labor time on the project.

This LED retrofit will improve the look and feel of your space while delivering significant energy savings, improved light quality and long life with zero maintenance.

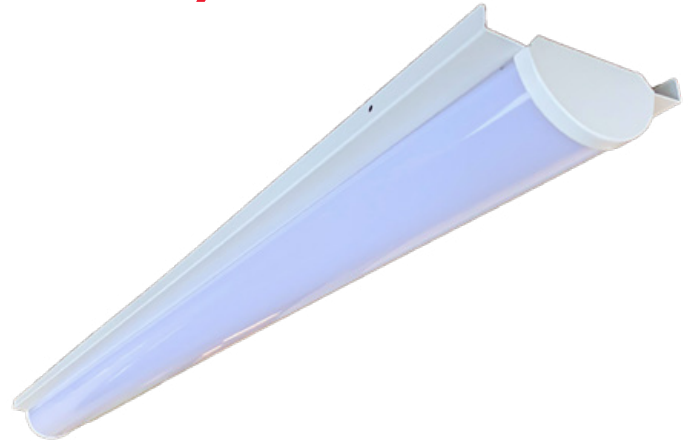

FEATURES

- Selectable wattage/CCT
- Shatterproof lens makes it safe for food service applications
- Available in 4' and 8' lengths
- 4' & 8' strips are connectable with Harness accessory, ordered separately.
- Fits 4.25" width strips, 5" are made to order
- 50,000-hour rated life (@L70)
- 5-year warranty
- DLC 5.1 Premium
- Compatible with Emergency Battery Backup
- 0-10V dimming
- 120-277V

MOUNTING

- Mounts to existing housing

APPLICATIONS

- Healthcare and hospitals
- Schools and universities
- Sports facilities & gyms
- Retail
- Corridors
- Task areas
- Aisles

LITETRONICS DIFFERENCE

- Contractor value pricing
- Quick connect
- DLC Premium

CERTIFICATIONS



SPECIFICATIONS

Life (@L70): 50,000 hours

Warranty: 5 years

PERFORMANCE

Operating temp: 32°F to 113°F (0°C to 45°C)

Efficacy (LPW): 125 LPW

CRI: 80

ELECTRICAL

Input voltage: 120-277V

Input frequency: 50/60Hz

PF: ≥.95

THD: N/A

Surge protection: N/A

Dimming: 0-10V

Minimum dimming: N/A

Aux. Power Tap: N/A

Driver CL: N/A

Whip/Cord: N/A

Sensor: N/A

OPTICAL

Beam: 120°

Lens: Polycarbonate Frosted

UGR: N/A

PHYSICAL

Finish: Powder Coat

Color: White

Housing: Painted Steel

INDUSTRY STANDARDS/RATINGS

IP: 20

IK: N/A

Location: Damp

IC: N/A

UL: No

ETL: N/A

FCC: Yes

RoHS: Yes

DLC: 5.1 Premium

MOUNTING

CONTINUOUS MOUNTING

The Strip Fixture can be continuously mounted from one power source. Below are the total units that can be connected per wattage setting.

LENGTH	WATTS	MAX CAN BE CONNECTED IN ROW	HOW MANY REQUIRED	
			SFAM06	SFAM07
106	15	53	52*	
88	18	44	43*	
80	20	40	39*	
64	25	32	31*	
108	30	27	26	
80	40	20	19	
128	46	16		16
60	50	15	15	15
96	60	12		12
80	70	10		10
72	80	9		9

* for SFS2 (2ft fixture) use SFAM06 of 4' length if required.

SIZING

ORDER#	SIZE
SRCS4	4'
SRCS8	8'

DIMENSIONS / WEIGHT

ORDER#	LENGTH	WIDTH	HEIGHT	WEIGHT
SRCS4	47.795"	4.252"	2.95"	6.21 lbs
SRCS8	95.81"	4.252"	2.95"	7.03 lbs

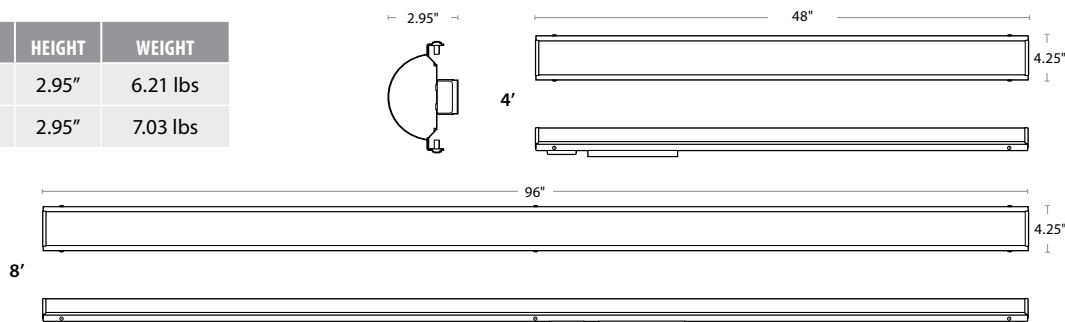

ORDERING INFORMATION

SELECTABLE WATTAGE & CCT

ORDERING CODE	DESCRIPTION	SIZE	WATTS	VOLTS	CCT (K)	LUMENS
SRCS4	4.25" Wide 4' LED Strip Retrofit with Selectable Output	4'	18, 25, 30, 40	120-277	3500, 4000, 5000	2250, 3125, 3750, 5000
SRCS8	4.25" Wide 8' LED Strip Retrofit with Selectable Output	8'	46, 60, 70, 80	120-277	3500, 4000, 5000	5750, 7500, 8750, 10000

Note: 5" width strips are made to order.

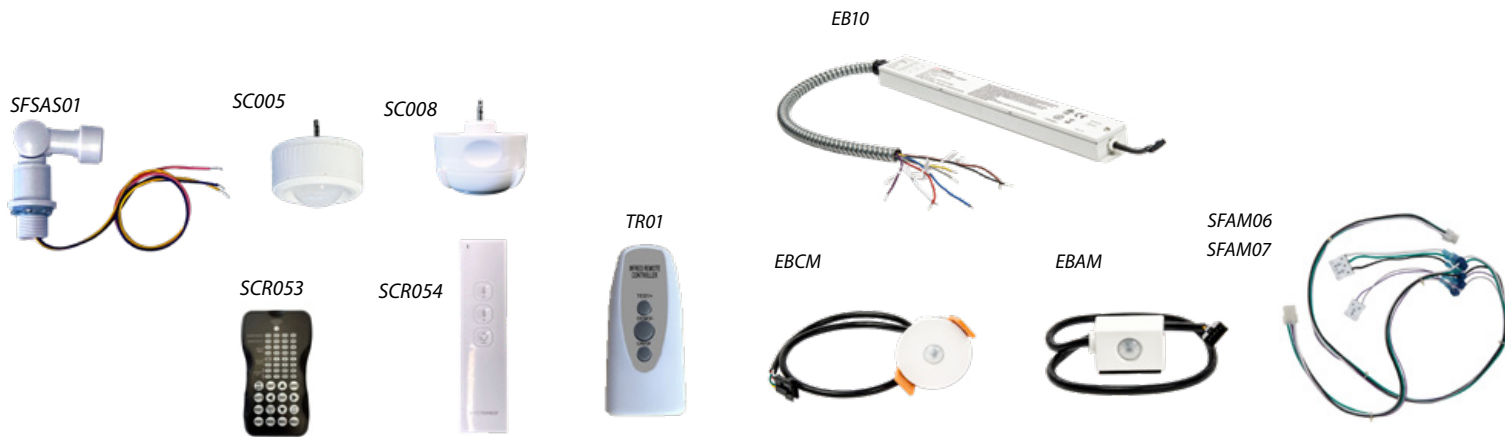

MODEL #	DESCRIPTION	USAGE
SFSAS01	Strip Series Elbow with 3 Wires for Pluggable Sensor	Ordered separately - Required for Plug-In sensors SC005 and SC008.
SC005	Plug-in PIR Sensor	Enable occupancy sensing and daylight harvesting on pluggable fixtures
SC008	Plug-in Bluetooth PIR Sensor with IR	This sensor enables wireless control of fixtures, or groups of fixtures, through the LiteSmart mobile app.
SCR053	Remote Control	Used (with SC005 and SC006 sensor) to adjust settings after installation
SCR054	Remote Control	Used to Commission LiteTronics "Next Generation" LiteSmart IR-Enabled Sensor.
TR01	Test Remote Control	Used for testing and demonstrating the functionality of EB10 emergency battery backup integrated products. <ul style="list-style-type: none"> • Only one remote required per area, building or site as necessary.
EB10	10W Emergency Battery Backup	Supplies battery backup to an individual fixture for up to 90 minutes. <u>Must be ordered with EBCM or EBAM indicator module.</u>
EBCM	Ceiling-Mounted Indicator Module	This Ceiling-Mounted Indicator Module (EBCM) can be used with one of Litetronics' emergency battery backup products (EB10, EB10N or EB20) to provide a visual confirmation of the operational status of the EBB unit. This module is typically used in grid ceiling applications where it is recess mounted in a panel adjacent to the fixture.
EBAM	Adhesive-Mounted Indicator Module	This Adhesive-Mounted Indicator Module (EBAM) must be used with one of Litetronics' emergency battery backup products (EB10, EB10N or EB20) to provide a visual confirmation of the operational status of the EBB unit. This module is typically used in open ceiling or drywall ceiling applications where the module is applied to the side of the fixture, mounting kit, or a nearby structural element.
SFAM06	Strip Fixture Wire Harness Connecting Kit for 4'	Used to connect two or more strip fixtures together from one power source.
SFAM07	Strip Fixture Wire Harness Connecting Kit for 8'	Used to connect two or more strip fixtures together from one power source.