

LITETRONICS®

LED Light Panel

Watt and CCT Selectable with Sensor Socket

Installation Instructions

PT*S - Series | 1' x 4', 2' x 2', & 2' x 4'

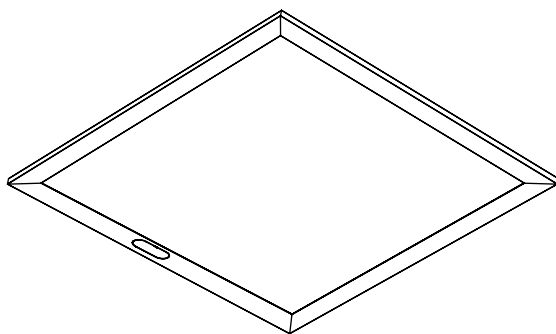

WHAT COMES IN THE BOX

LED Back Lit Panel
Wire Nut (x5)
Installation Instructions

TOOLS NEEDED

Wire Stripper
Wire Cutter
Phillips Screwdriver

SAFETY INSTRUCTIONS AND WARNINGS

WHEN USING ELECTRICAL EQUIPMENT, BASIC SAFETY PRECAUTIONS SHOULD ALWAYS BE OBSERVED. READ CAREFULLY BEFORE INSTALLING FIXTURE. RETAIN THESE INSTRUCTIONS FOR FUTURE REFERENCE.

Litetronics fixtures must be wired in accordance with the National Electrical Code and all applicable local codes.

Risk of fire or electric shock. LED Back Lit Panel installation requires knowledge of luminaires electrical systems. If not qualified, do not attempt installation. Contact a qualified electrician.

Be certain electrical power is OFF before and during installation and maintenance.

LED Back Lit Panel must be connected to a wiring system with an equipment – grounding conductor.

Make sure the supply voltage is the same as the rated luminaire voltage.

Only the open holes indicated in the photographs and/or drawings may be made or altered as a result of this kit installation. Do not leave any other open holes in an enclosure of wiring or electrical components.

To prevent wiring damage or abrasion, do not expose wiring to edges of sheet metal or sharp objects.

No user serviceable parts inside of LED Back Lit Panel.

Suitable for damp locations.

Suitable for 9/16" or 15/16" Flat Tee Grid in both insulated ceilings and non-insulated ceilings. Access above ceiling required.

Vapor barrier must be suitable for 90° C.

Fixture to be independently supported to building structure.

INSTALLATION PROCEDURE

READ ALL INSTRUCTIONS BEFORE BEGINNING INSTALLATION

1. Turn off power at the electrical panel.
2. Remove the ceiling tile or existing fixture from the grid ceiling space.
3. Before installing, locate the grid clips on your panel; bend them up and out so they can rest on top of the grid.
4. Unscrew and remove the driver cover to access the input, ground and dimming wires.
5. Locate the adjustable wattage and CCT slide switch on the side of the driver and set to the desired wattage. See slide switch settings below.

CCT SLIDE SWITCH SETTINGS

5000K	4000K	3500K	3000K
-------	-------	-------	-------

* **Note:** CCT default setting set to 4000K.

WATTS SLIDE SWITCH SETTINGS 1' X 4' & 2' X 2'

18W	20W	25W	30W	36W
-----	-----	-----	-----	-----

* **Note:** Watts default setting set to 36W.

WATTS SLIDE SWITCH SETTINGS 2' X 4'

25W	30W	40W	45W	50W
-----	-----	-----	-----	-----

* **Note:** Watts default setting set to 50W.

6. Tilt and raise the panel up into the empty grid space, then lower until the grid clips catch on the tee-grid bar. Attach the panel to the building with support wires (not included) using the hole in the grid clip.
7. Remove one conduit knock-out from the driver cover, then run branch power wire from the conduit to the driver cover.
8. Follow wiring diagram, Figure 1.
 - a. Connect the green ground line with wire nut.
 - b. Connect the neutral (white) line to AC-N (white) with wire nut.
 - c. Connect the live power (black) line to AC-L (black) with wire nut.
 - d. If 0-10V dimming is required, connect incoming dimming lines from dimmer to the fixture Driver DIM+ (Purple), Sensor DIM+ (Purple), and DIM- (Gray/Pink) wires. Follow dimmer manufacturers instruction.

Note: If Bluetooth sensor (optional) is required then use sensor SC010 (sold separately).
9. Close the driver cover and secure it with the screw.
10. Replace the ceiling tiles, turn on the power and your installation is complete.

WIRING DIAGRAM

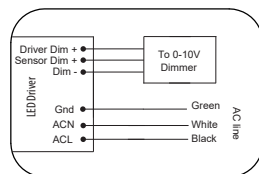
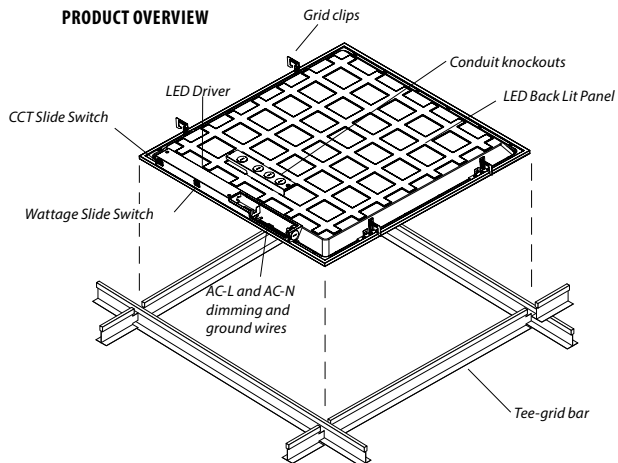

Figure 1

PRODUCT OVERVIEW



Thank you for choosing

LITETRONICS®

6969 W. 73rd Street
Bedford Park, IL 60638

WWW.LITETRONICS.COM

CustomerService@Litetronics.com or 1-800-860-3392



The information and product specifications contained in these instructions are based upon data believed to be accurate at the time of printing. This information is subject to change without notice and without incurring liability. If you have questions regarding specific product details, please contact us at 800-860-3392 or via email at customerservice@litetronics.com.

To check for an updated version of these instructions, please visit www.litetronics.com.

9/6/24 - V1.3