

LITETRONICS®

LED Smart Volumetric Troffer with Selectable CCT and Tunable Wattage

Installation Instructions

VLTA-Series | 2' x 2', 2' x 4' & 1' x 4'

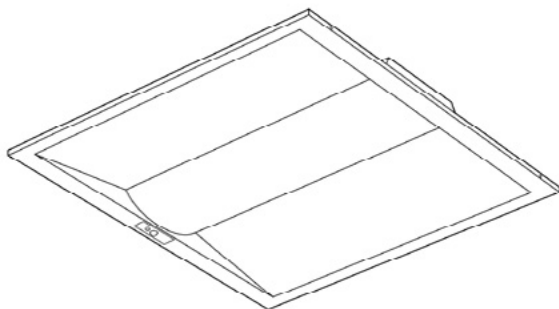

WHAT COMES IN THE BOX

LED Smart Volumetric Troffer
Wire Nut (3)
Installation Instructions

TOOLS NEEDED

Phillips Screwdriver

SAFETY INSTRUCTIONS AND WARNINGS

WHEN USING ELECTRICAL EQUIPMENT, BASIC SAFETY PRECAUTIONS SHOULD ALWAYS BE OBSERVED. READ CAREFULLY BEFORE INSTALLING FIXTURE. RETAIN THESE INSTRUCTIONS FOR FUTURE REFERENCE.

Litetronics fixtures must be wired in accordance with the National Electrical Code and all applicable local codes.

Risk of fire or electric shock. Volumetric Troffer installation requires knowledge of luminaires electrical systems. If not qualified, do not attempt installation. Contact a qualified electrician.

Be certain electrical power is OFF before and during installation and maintenance.

Volumetric Troffer must be connected to a wiring system with an equipment – grounding conductor.

Make sure the supply voltage is the same as the rated luminaire voltage.

Only the open holes indicated in the photographs and/or drawings may be made or altered as a result of this kit installation. Do not leave any other open holes in an enclosure of wiring or electrical components.

To prevent wiring damage or abrasion, do not expose wiring to edges of sheet metal or sharp objects.

No user serviceable parts inside of the Volumetric Troffer.

Suitable for damp locations.

Suitable for 9/16" or 15/16" Flat Tee Grid in both insulated ceilings and non-insulated ceilings. Access above ceiling required.

Vapor barrier must be suitable for 90° C.

Fixture to be independently supported to building structure.

INSTALLATION PROCEDURE

INSTALLATION INSTRUCTIONS

1. Turn off power at the electrical panel.
2. Remove the ceiling tile or existing fixture from the grid ceiling space.
3. Before installing, locate the grid clips on your troffer; bend them up and out so they can rest on top of the grid.
4. Unscrew and remove the driver cover to access the input ports, ground and dimming wires.
5. Locate the adjustable CCT slide switch on the top of the driver and set to the desired CCT. See slide switch settings below.
6. Tilt and raise the troffer up into the empty grid space, then lower until the grid clips catch on the tee-grid bar. Attach the troffer to the building with support wires (not included) using the hole in the grid clip.
7. Remove one conduit knock-out from the driver, then run branch power wire from the conduit to the driver.
8. Connect power wires AC-L (Black) and AC-N (White) and ground wires (Green & Yellow) into corresponding driver wires.
9. Close the driver cover and secure it with the screw.
10. Replace the ceiling tiles, turn on the power and your installation is complete.

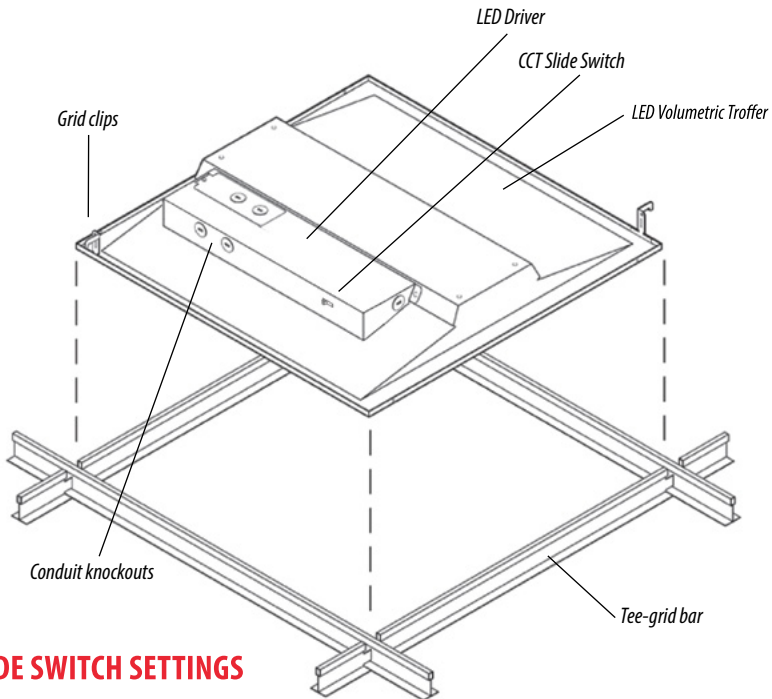

CCT SLIDE SWITCH SETTINGS

5000K	4000K*	3500K
-------	--------	-------

* **Note:** CCT default setting set to 4000K.

INSTALLATION PROCEDURE

SENSOR CONTROLS

The LED Smart Volumetric Troffer is equipped with a built-in PIR sensor, which enables wireless control of various functions, such as occupancy sensing, daylight harvesting and dimming.

The following options are available for controlling your LED Smart Volumetric Troffer.



LiteSmart* mobile app – Available in the app store for download to either IOS or Android devices.

LiteSmart offers complete control over your fixtures; includes occupancy sensing, daylight harvesting, dimming, grouping, time schedule programming and scene creation.

A supplemental app, **LiteBright***, enables additional energy management functionality with the ability to set the max wattage of your fixtures.



Bluetooth Control Switch – Available for purchase from Litetronics under part # **BCS01**, **BCS02**.

This wireless bluetooth switch offers control over your fixture from a remote location, enabling quick access to on/off functionality as well as dimming control, daylight harvesting and scene selection.

** A detailed user guide for LiteSmart can be viewed or downloaded from Litetronics.com*

SENSOR DEFAULT SETTINGS**

OCCUPANCY SENSING	HOLD TIME - FULL POWER	HOLD TIME - 50% POWER
On	20 minutes	1 minute

***To adjust settings for occupancy sensing, enable daylight harvesting or to group and program fixtures, download the LiteSmart mobile app.*

Thank you for choosing

LITETRONICS®

6969 W. 73rd Street
Bedford Park, IL 60638

WWW.LITETRONICS.COM

CustomerService@Litetronics.com or 1-800-860-3392



The information and product specifications contained in these instructions are based upon data believed to be accurate at the time of printing. This information is subject to change without notice and without incurring liability. If you have questions regarding specific product details, please contact us at 800-860-3392 or via email at customerservice@litetronics.com.

To check for an updated version of these instructions, please visit www.litetronics.com.

2/3/23-V1.3