

LITETRONICS®

Strip Fixture Motion Sensor Kit SFAS50

Installation Instructions

For Strip Fixtures

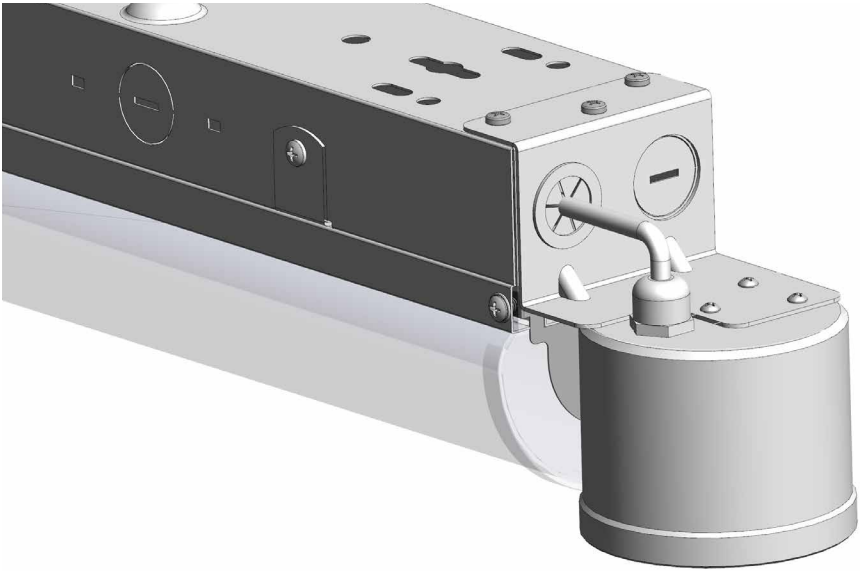

PLEASE READ THESE INSTRUCTIONS BEFORE INSTALLATION

SAFETY INSTRUCTIONS AND WARNINGS

WARNING:

READ CAREFULLY BEFORE INSTALLING

RETAIN THESE INSTRUCTIONS FOR FUTURE REFERENCE.

Sensor must be wired in accordance with the National Electrical Code and all applicable local codes.

Risk of fire or electric shock. Sensor installation requires knowledge of luminaire electrical systems. If not qualified, do not attempt installation. Contact a qualified electrician.

Be certain electrical power is OFF before and during installation and maintenance.

Make sure the supply voltage is same as the rated Sensor voltage

Only those open holes indicated in the photographs and/or drawings may be made or altered as a result of this kit installation. Do not leave any other open holes in an enclosure of wiring or electrical components.

Review the sensor settings section and complete any necessary DIP switch setting changes.

Mount the sensor so the lens is below the edge of the fixture and away from the lamps. Heat from the lamps could affect the sensor operation. Make sure that you have the appropriate accessories for the sensor mounting configuration.

Assemble any necessary mounting accessories and attach them to the sensor module. Make sure that the flying leads from the sensor module cable are accessible inside the fixture.

Connect the line voltage and load wires to the sensor leads as shown in the applicable wiring diagram for the sensor module.

Do not allow exposed bare wires.

Make sure all connections are secure.

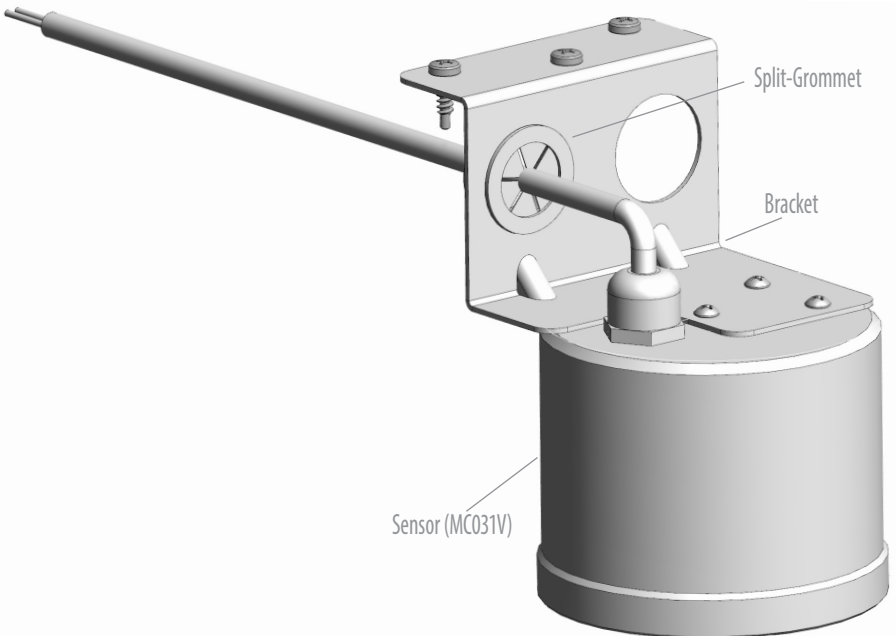

TOOLS TYPICALLY USED FOR INSTALLATIONS



Wire Stripper
(optional)

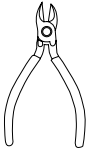

Wire Cutter
(optional)

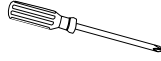

Phillips Screwdriver



Step Ladder

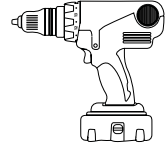

Drill

WHAT COMES IN THE BOX

Motion Sensor base product comes with following standard parts:

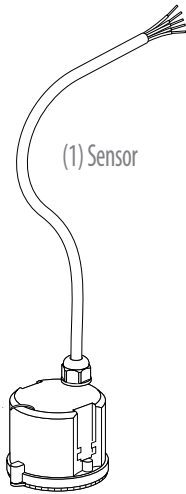

(1) Sensor

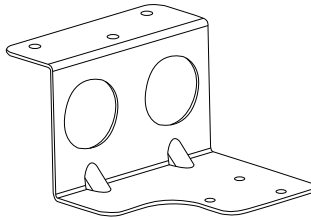

(1) Bracket



(1) Split-Grommet



(3) Self-tapping screws



(3) Mounting screws

*Before Installation, carefully remove all parts from the packaging.
Inspect product for defects due to shipping.*

MOTION SENSOR INSTALLATION

1. Turn off power at electrical panel.



2. Remove one knock out from strip fixture as desired.

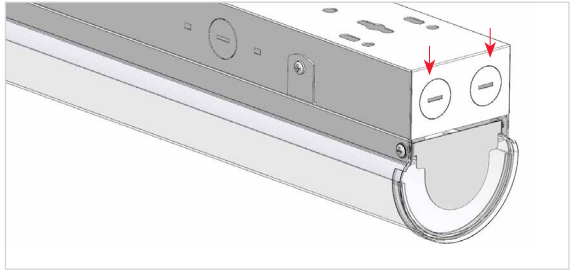

3. Attach bracket to sensor using 3 mounting screws included. Then attach sensor to strip fixture using 3 self-tapping screws included.

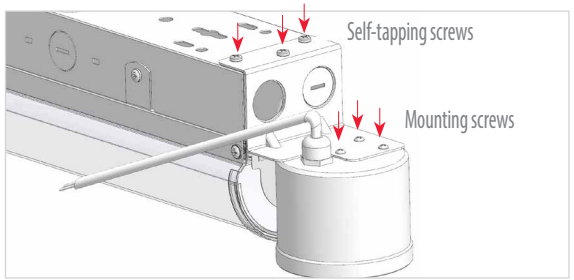

4. Pass the sensor cable through split grommet, then attach to strip fixture by inserting into hole.
Note: You may want to leave slack for wiring, then attach grommet to strip fixture after wiring is complete.

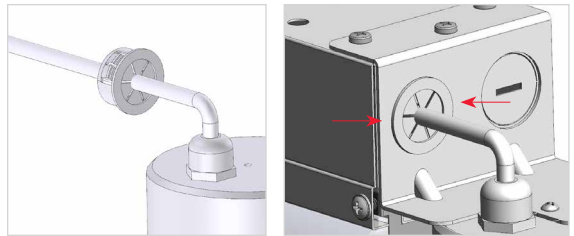

MOTION SENSOR INSTALLATION

5. With the strip fixture opened, follow below wiring diagram for connections.

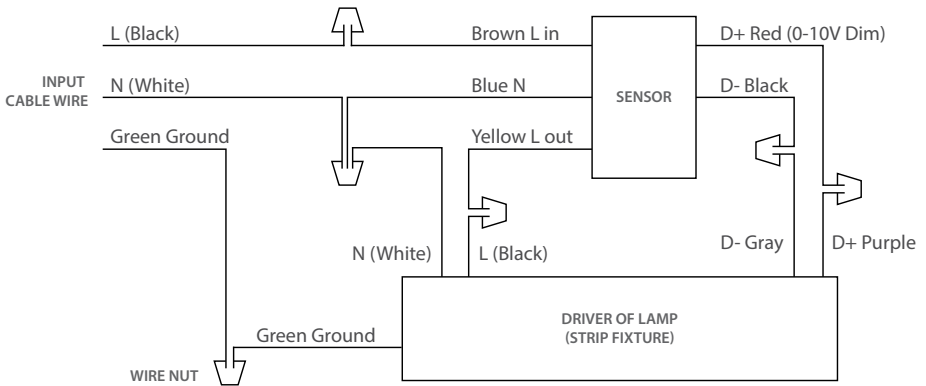
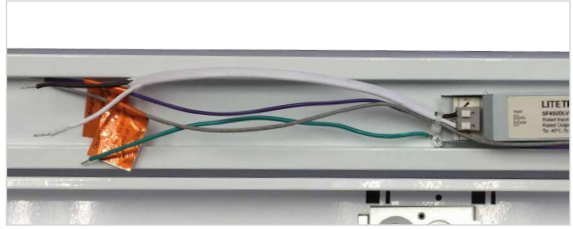

6. Continue installation using Strip Fixture Install instructions.



MOTION SENSOR INSTALLATION

7. To set sensor functionality, remove screw from plastic cover on sensor and then unscrew top cover from sensor assembly. You will see dip switch.



MC031V SENSOR SETTINGS

By setting the DIP switch, sensor data can be precisely set for each specific application.

Factory default settings

	1	2	3	4	5	6	7	8	9	10	11	12
ON ↑ 	ON	ON	ON	ON	-	-	-	-	-	ON	ON	ON

ON ↑ 		1	
	I	ON	100%
	II	—	50%

Detection area

Detection area can be reduced by selecting the appropriate combination on the DIP switches.

ON ↑ 		2	3	4	
	I	ON	ON	ON	5s
	II	—	ON	ON	30s
	III	ON	—	ON	90s
	IV	—	—	ON	3min
	V	ON	ON	—	20min
	VI	—	—	—	30min

Hold Time

Sets the time period the lamp remains at 100% illumination after no motion detected.

ON ↑ 		5	6	7	
	I	ON	ON	ON	+∞
	II	—	ON	ON	60min
	III	ON	—	ON	30min
	IV	—	—	ON	10min
	V	ON	ON	—	5min
	VI	—	—	—	5s

Stand-by period

Controls the time period the lamp remains at a low light level before it completely switches off in the long absence of people. When set to +∞, the low light is maintained until motion is detected.

MOTION SENSOR INSTALLATION

		8	9	
	I	ON	ON	50%
	II	—	ON	30%
	III	ON	—	20%
	IV	—	—	10%

Stand-by dimming level

Determines the light level you would like to have after the hold time in the long absence of people.

		10	11	12	
	I	ON	ON	ON	Disable
	II	—	ON	—	200lux
	III	ON	—	—	100lux
	IV	—	—	—	50lux

Daylight sensor

The sensor can be set to only allow the lamp to illuminate below a defined ambient brightness threshold.

When set to Disable mode, the daylight sensor will switch on the lamp when motion is detected regardless of ambient light level.

Note that daylight sensor is active only when lamp totally switches off.

TROUBLESHOOTING

REASON	CAUSE	REMEDY
The load will not illuminate	Incorrect daylight sensor setting selected.	Adjust setting.
	Load had failed.	Replace load.
	Power is switched off.	Switch on.
The load is permanently illuminated.	Continuous movement in the detection area.	Check detection area setting.
	The lamp (Containing sensor) is installed in an area too close to reflective surfaces, i.e. metal, glass or concrete walls.	<ul style="list-style-type: none"> • Make sure installation area suitable with at least 30 cm space between lamp and surrounding reflective surfaces. • Reduce sensitivity (Detection are).
The load will not illuminate despite movement.	Speed of moving object is not in the range of 0.5~3m/s or the detection radius is too small.	Check detection area setting.

Thank you for choosing

LITETRONICS®

6969 W. 73rd Street
Bedford Park, IL 60638

WWW.LITETRONICS.COM

CustomerService@Litetronics.com or 1-800-860-3392

