

IP65 Microwave Motion Sensor for Round High Bays



Designed Specifically for Quick and Easy Installation.

The Litetronics IP65 Microwave Motion Sensor for High Bay offers automatic dimming when used in combination with 1-10V dimmable LED drivers or ballasts. With a built-in adjustable daylight sensor 1-10V interface, the detection area, time delay and daylight threshold can be precisely set via DIP switch. Enjoy peace of mind and savings with a wide detection area range of up to 52ft in diameter and mounting height of 49ft max.

Benefits

- Waterproof IP 65
- No junction box required
- 0-10V capability
- Programmable sensor
- 52ft diameter detection zone
- Up to 49ft max. mounting height
- 150° detection angle

Markets & Applications

- Retail
- Warehouse
- Industrial
- Gyms
- Transit Facilities
- Garages

LITETRONICS®

6969 W. 73rd Street
Bedford Park, IL 60638
www.Litetronics.com

IP65 Microwave Motion Sensor

for Round High Bays

Technical Product Information

Volts: 120-277V

Base: Waterproof Twist Connector

Weight: 0.8lbs.

Operating Temp.: -31°F to 158°F

Part Number Matrix

XX (product family)	X (family)	XX(number)
HBA - LED High Bay Accessory	S - Sensor	47 - Accessory Number

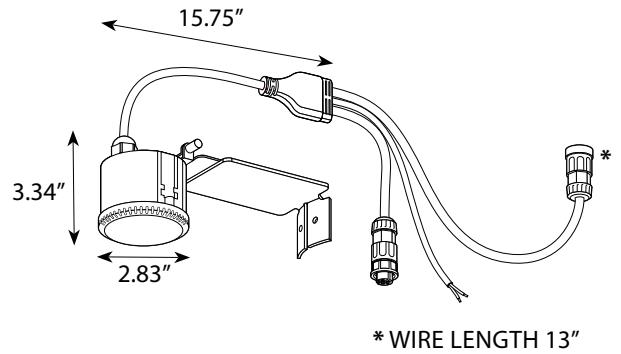

Specifications

LOAD	DESCRIPTION	ORDERING CODE	QTY/ CASE*	ACCESSORY USE
400W@120VAC, 800W@220-277VAC	MICROWAVE MOTION SENSOR IP65 120-277V AND 0-10V	HBAS47	10	IP65 microwave motion sensor for wet locations consist of a sensor and a lens module and preconnected bracket. Detection area, time delay and daylight threshold can be precisely set via DIP switch

What's included in the box with IP65 Microwave Motion Sensor:

Installation Instructions • (1) IP65 Microwave Motion Sensor • (2) Self-tapping Screws

Product Overview

