

PROJECT:	
CATALOG #	
TYPE:	DATE:

LED STRIP FIXTURE

DESCRIPTION

The LED Strip Fixture is a modern, energy-efficient, linear lighting solution that delivers consistent, high-quality light distribution, minimal energy usage and zero maintenance.

The fixture is available in either 4' or 8' lengths and can be surface, suspension, or t-grid mounted, either in a single-fixture configuration or as a continuous row to cover more ground from one power source. The lightweight, two-piece design makes installation quick and easy, reducing overall project time.



FEATURES

- 145 lumens per watt (lm/W)
- DLC Premium
- ETL rated for damp locations
- 10-year warranty
- 100,000-hour rated life (@L70)
- Continuous row mounting (daisy chaining)
- Shatterproof polycarbonate lens
- 0-10V dimming (0% minimum)
- Polycarbonate frosted lens with translucent end caps
- Available in 4' and 8' lengths

SPECIFICATIONS

- Input voltage: 120-277V
- Operating temp: -4°F – 113°F
- Beam angle: 120°
- CRI: >80
- Lumens per Watt: 145
- Surge protection: 2KV
- Power factor: > 0.9
- THD (Max): <20
- Input frequency: 50/60
- IP rating: 20
- Average rated life (@L70): 100,000-hours
- Warranty: 10-years
- ETL listed: Yes
- Location rating: Damp
- DLC rating: Premium
- RoHS Compliant: Yes

APPLICATIONS

- Commercial
- Industrial
- Retail
- Manufacturing
- Warehouse
- Display
- Corridors
- Storage
- Stairways

DIMENSIONS

SIZE	LENGTH	WIDTH	HEIGHT	WEIGHT
4'	48.04"	3.26"	2.95"	3.75 lbs
8'	95.98"	3.26"	2.95"	7.2 lbs

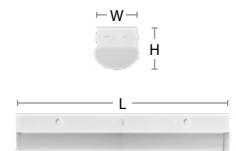

MOUNTING

- Surface
- Suspension
- Continuous row
- T-grid (standard or angled for wall wash applications)

CERTIFICATIONS



ORDERING

ORDERING CODE	DESCRIPTION	WATTS	CCT	LUMENS
SF40S440	4' 40W LED Strip Fixture in 4000K	40	4000	5,800
SF60S840	8' 60W LED Strip Fixture in 4000K	60	4000	8,700

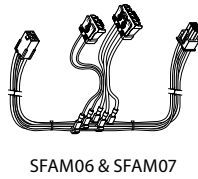
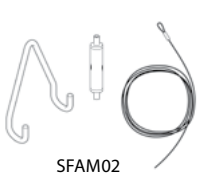

ORDERING CODE	DESCRIPTION	USAGE
SFAM02	Suspension Mount Kit	Suspend Strip Fixtures from ceiling surface. Note: Two kits needed for 8' assembly. Cable is 5' in length. Weight rating is 25 lbs.
SFAM06	4' Wire Harness Kit	Connect two or more 4' Strip Fixtures together from one power source.
SFAM07	8' Wire Harness Kit	Connect two or more 8' Strip Fixtures together from one power source.
EB10	10W Emergency Battery Backup	Supplies battery backup to an individual fixture for up to 90 minutes. <u>Must be ordered with EBCM or EBAM indicator module.</u>
EBCM	Ceiling-mounted Indicator Module	In grid ceiling applications, this unit connects to the EB10 and is recess mounted in an adjacent panel where it displays the unit's current status of operation.
EBAM	Adhesive-mounted Indicator Module	In drywall/open ceiling applications, this unit connects to the EB10 and is mounted via adhesive, where it displays the unit's current status of operation.

OVERVIEW AND INSTALLATION

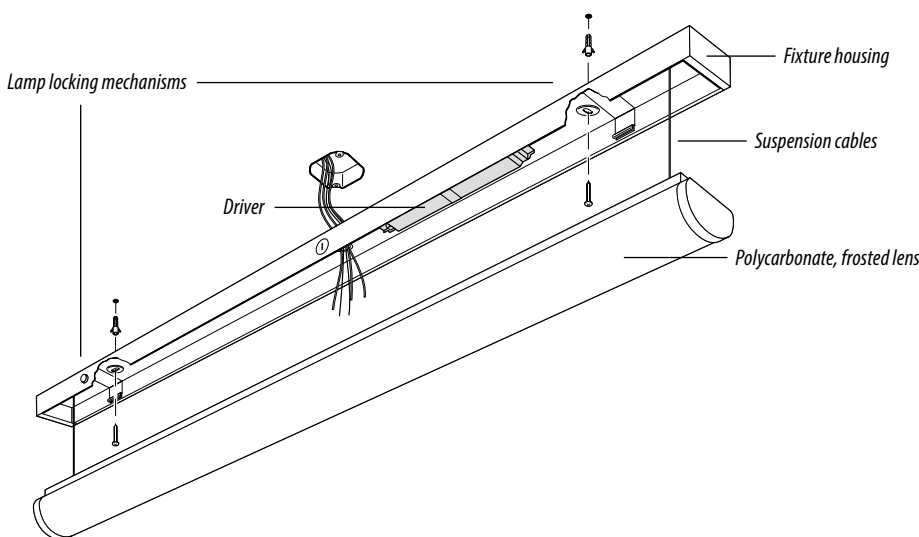

Continuous Mounting

The Strip Fixture can be continuously mounted from one power source. Below are the total units that can be connected per wattage.

WATTAGE	TOTAL UNITS
40	33
60	22

HAVE QUESTIONS?

Our Customer Service team can help. Call us at 800-860-3392 or send an email to customerservice@litetronics.com